

University of Asia Pacific
Department of Civil Engineering
Final Examination Spring 2013
Program: B.Sc. Engineering (Civil)

Course Title: Structural Engineering II
 Time: 3 hours

Credit Hours: 3.0

Course Code: CE 313
 Full Marks: 100 (=10 × 10)

(There are 14 questions. Answer any 10)

1. For the structure shown below, use the Portal Method to
 - (i) Draw the bending moment diagrams of the top floor beams AB and BC
 - (ii) Calculate the applied load F_1 if the maximum bending moment in column EH is 30 k-ft.

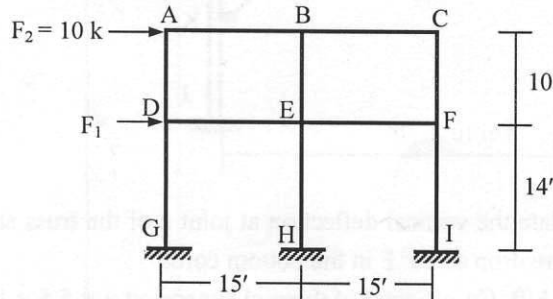

2. The figure below shows the axial forces (kips) in the exterior columns of a two-storied frame. If the cross-sectional area of column ABC is twice the area of the other columns, use the Cantilever Method to calculate the corresponding applied loads P_1 and P_2 .

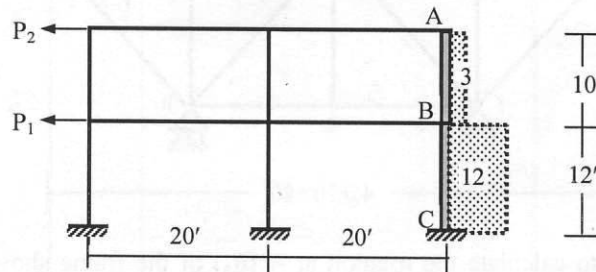

3. Analyze the two-storied frame structure loaded as shown below using the approximate location of hinges to draw the bending moment diagrams of the beams and columns.

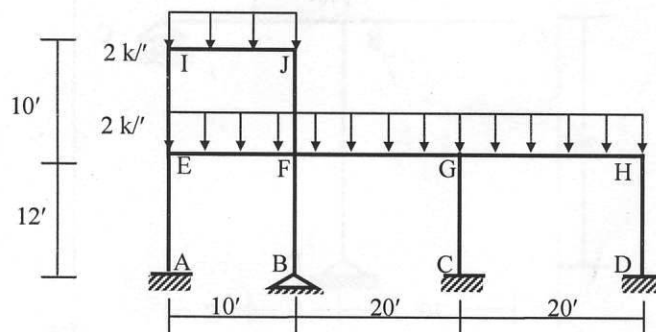

4. In the mill bent shown below

- (i) Use the Portal Method to draw the bending moment diagram of the column ABC.
- (ii) Calculate the forces in GI and FH, assuming them to take equal share of the sectional shear.

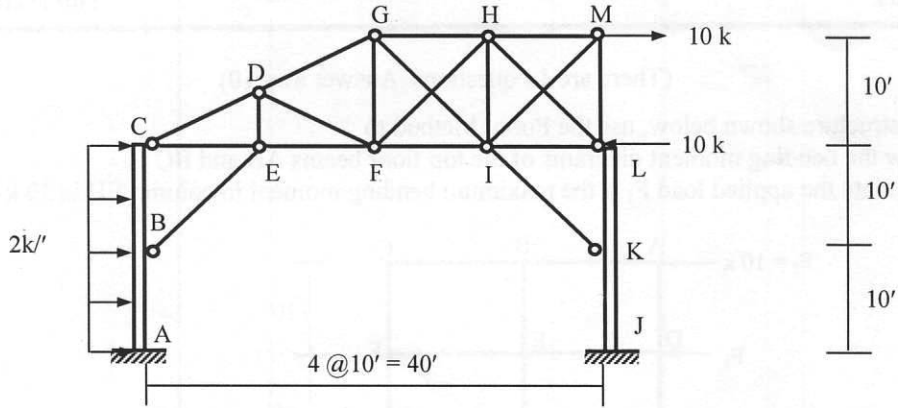

5. Use Unit Load Method to calculate the vertical deflection at joint c of the truss shown below due to

- (i) Applied loads, (ii) Temperature drop of 20°F in the bottom chords

[Given: $EA/L = \text{constant} = 1000 \text{ k/ft}$, Co-efficient of thermal expansion $\alpha = 5.5 \times 10^{-6}/^\circ\text{F}$].

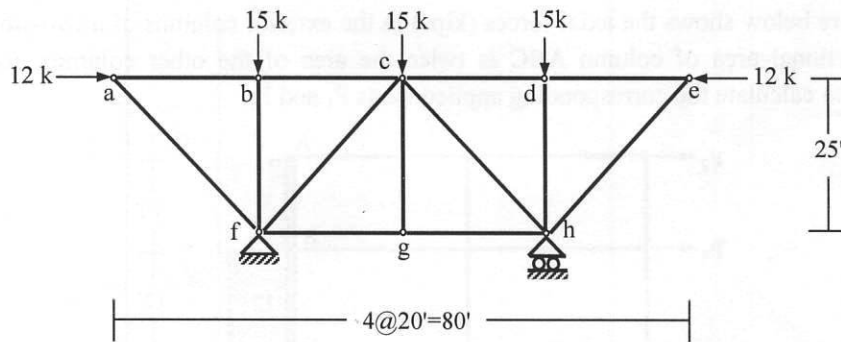

6. Use Unit Load Method to calculate the rotation at A (θ_A) of the frame shown below, considering axial, shear and flexural deformations [Given: $EA = 400 \times 10^3 \text{ k}$, $GA^* = 125 \times 10^3 \text{ k}$, $EI = 40 \times 10^3 \text{ k-ft}^2$].

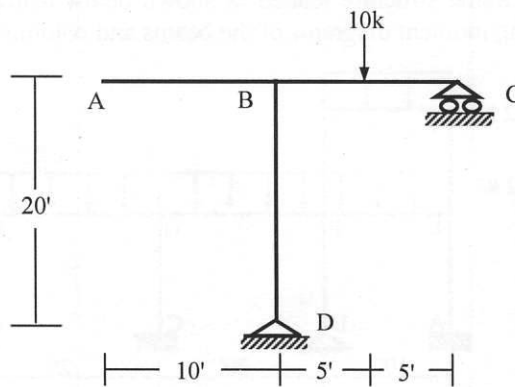

7. Use the Virtual Work Method (considering flexural deformation only) to calculate the vertical deflection at point C of the beam shown below [Given $EI = 40,000 \text{ k-ft}^2$].

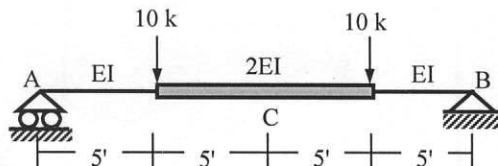

8. Use the Flexibility Method to draw the BMD of the beam shown below, if in addition to the applied load, support C settles down 0.10' [Given: $EI = 40 \times 10^3 \text{ k-ft}^2$].

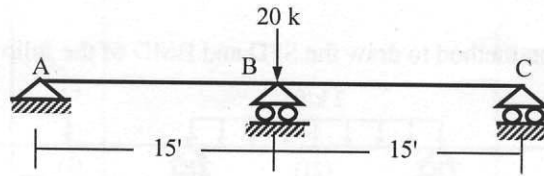

9. Use the Flexibility Method to calculate the bar forces of the truss shown below, if in addition to the applied loads, support C settles down 0.10' [Given: $EA/L = 1000 \text{ k/ft}$].

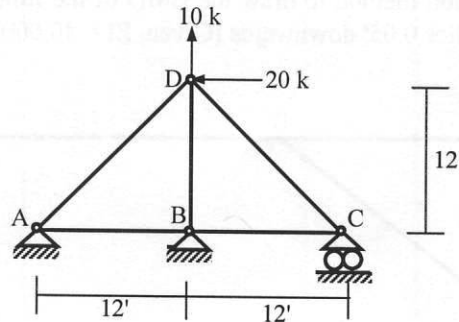

10. Use the Flexibility Method (considering flexural deformations only) to draw the bending moment diagram of the frame shown below, if support f settles 15-mm downward [Given: $EI = \text{constant} = 20 \text{ MN-m}^2$].

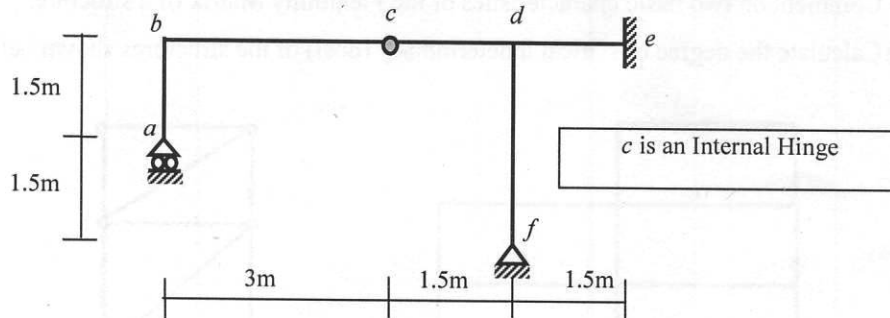

11. Draw the BMD of the following beam using the Moment Distribution Method [Given: $EI = \text{constant}$].

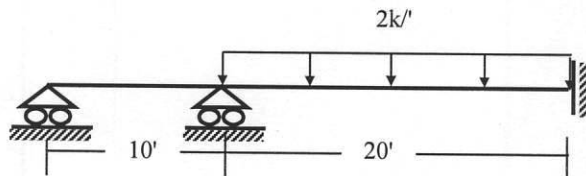

12. Use the Moment Distribution method to draw the SFD and BMD of the following beam.

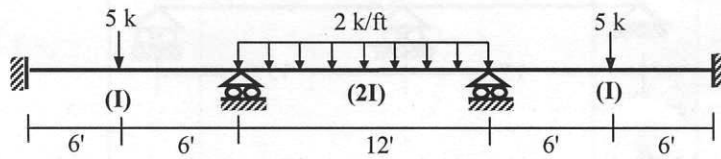

13. Use the Moment Distribution method to draw the BMD of the following frame if in addition to the applied load, support E settles 0.05' downwards [Given, $EI = 40,000 \text{ k-ft}^2$].

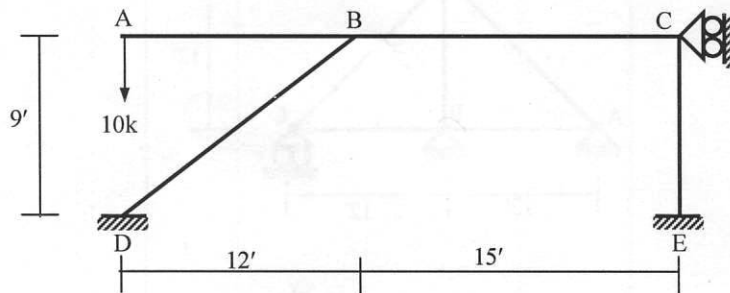

14. (i) Write down the basic difference between Lateral Load Analysis by Portal and Cantilever Method.
 (ii) Comment on two basic characteristics of the Flexibility Matrix of a structure.
 (iii) Calculate the degree of statical indeterminacy (dosi) of the structures shown below.

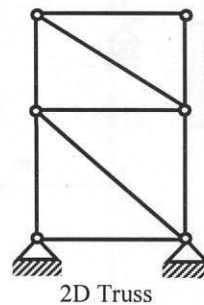
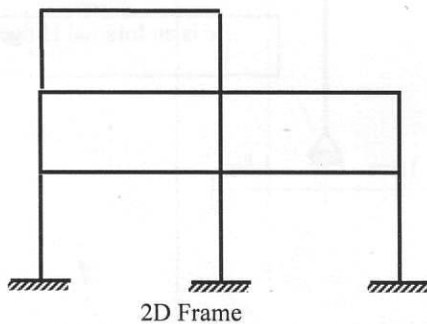

University of Asia Pacific
Department of Civil Engineering
Final Examination Spring 2013
Program: B. Sc. Engineering (Civil)

Course Title : Structural Engineering II
 Time : 3 hours

Course Code: CE 313
 Full Marks : 100

[Answer any 10 (ten) of the following 14 (fourteen) questions]

1. In the bridge portal shown below, use the Portal Method to draw the SFD and BMD of the column ABC.

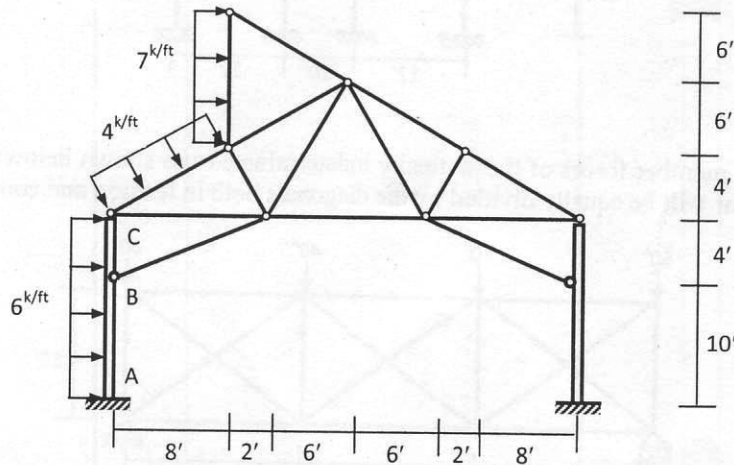

2. For the 2-storied frame loaded as shown, use the Portal Method to draw the SFD and BMD of the columns and the beams.

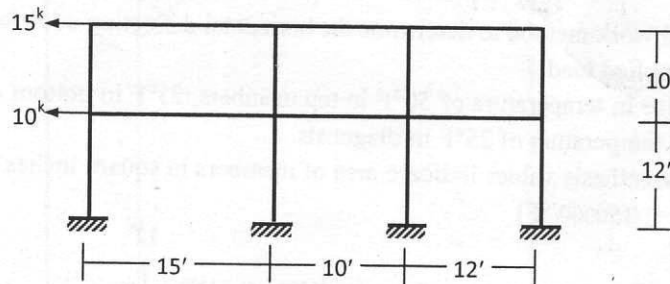

3. For the structure shown below, use the Cantilever Method to draw the AFD of the columns, SFD and BMD of the beams. Assume all column areas are equal.

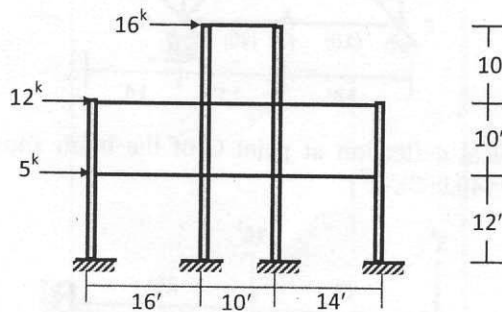

4. For the 2-storied frame structure loaded as shown below, use the approximate location of hinges to draw the SFD and BMD of the beams and columns.

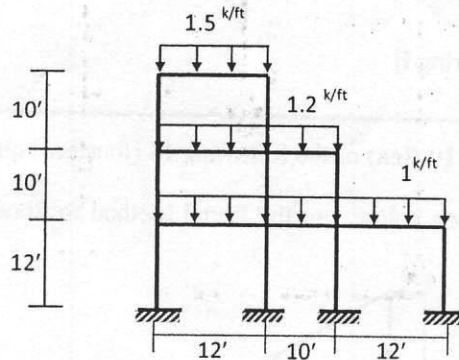

5. Calculate member forces of the statically indeterminate truss shown below assuming that full panel shear will be equally divided by the diagonals both in tension and compression.

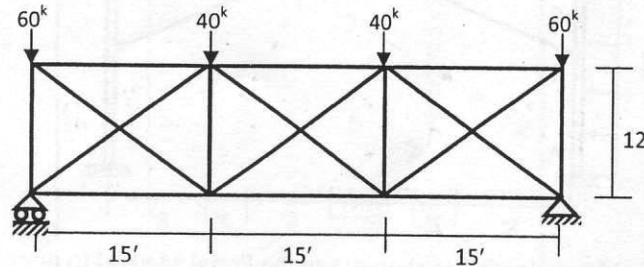

6. Use virtual work method to determine the horizontal deflection of A for
- Applied load
 - Rise in temperature of 50°F in top members, 25°F in bottom chord members and fall in temperature of 25°F in diagonals.
- Parenthesis values indicate area of members in square inches [Given, $E = 30 \times 10^3$ ksi, $\alpha_t = 1/150000/^{\circ}\text{F}$]

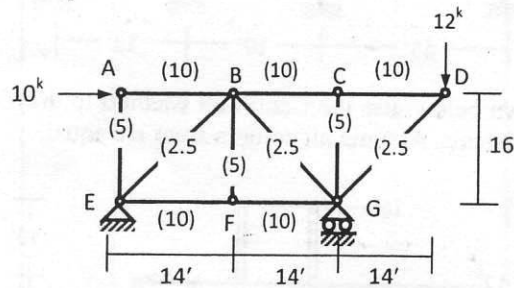

7. Calculate the vertical deflection at point C of the beam shown below using virtual work method [Given $EI = 40,000\text{k-ft}^2$].

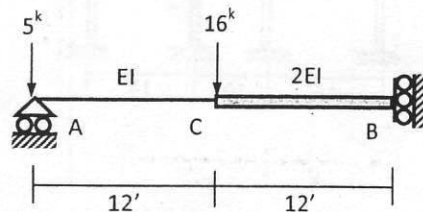

8. Use the virtual work method to calculate the vertical deflection at joint B of the frame shown below [Given, $EA = 400 \times 10^3$ k, $GA^* = 125 \times 10^3$ k, $EI = 40 \times 10^3$ k-ft²]

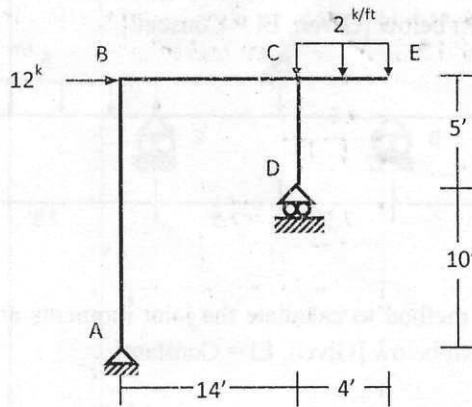

9. Use the flexibility method to calculate the member forces of the truss shown below, if in addition to the applied load, support A moves 0.10' leftward [Given, $EA/L = 1000$ kips/ft]

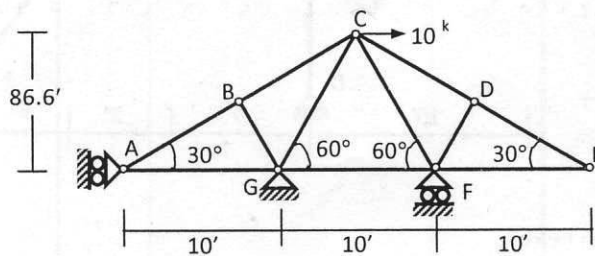

10. Use the flexibility method (considering flexural deformation only) to draw the bending moment diagram of the beam shown below, if in addition to the applied load, support A settles 0.10' downward [Given, $EI = 40 \times 10^3$ k-ft²]

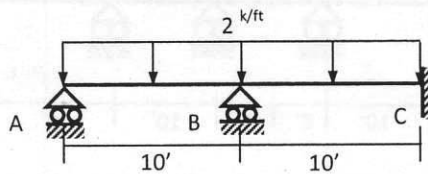

11. Using flexibility method, draw the bending moment diagram of the frame shown below [Given, $EA = 400 \times 10^3$ k, $GA^* = 125 \times 10^3$ k, $EI = 40 \times 10^3$ k-ft²]

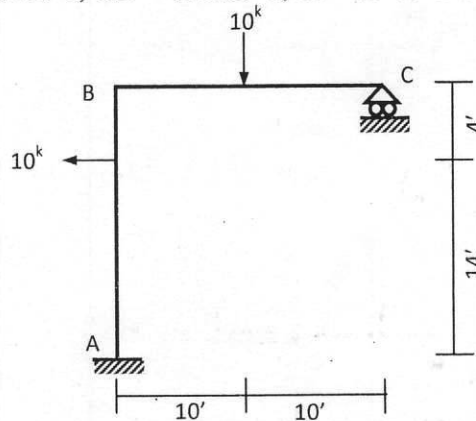

12. Use moment distribution method to calculate the joint moments and draw bending moment diagram of the beam shown below [Given, $EI = \text{Constant}$]

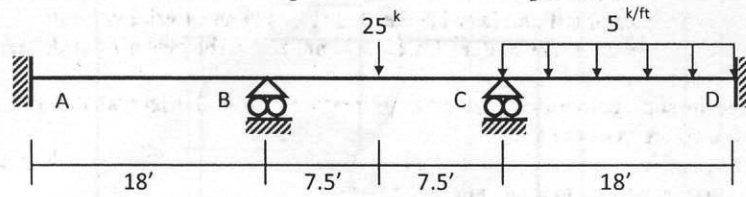

13. Use moment distribution method to calculate the joint moments and draw bending moment diagram of the frame shown below [Given, $EI = \text{Constant}$]

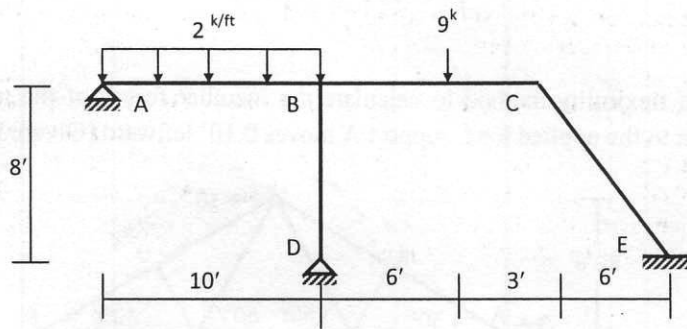

14. For the beam shown below,
 (i) Draw the qualitative influence lines for R_A , $V_{C(L)}$ and M_f .
 (ii) Calculate the maximum positive value of M_f , if the beam is subjected to a uniformly distributed DL = 1.5 k/ft and moving LL = 0.5 k/ft (uniformly distributed) and 3 k (concentrated) [Given, $EI = \text{Constant}$]

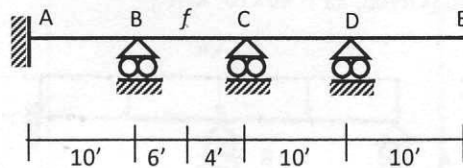

List of Useful Formulae for CE 313

*Portal Method for multi-storied frames assumes

- The shear force in an interior column is twice the shear force in an exterior column.
- There is a point of inflection at the center of each column, and at the center of each beam.

* Cantilever Method is based on three assumptions

- The axial force in each column of a story is proportional to its horizontal distance from the center of gravity of all the columns of the story.
- There is a point of inflection at the center of each column, and at the center of each beam.

*Vertical Analysis based on approximate location of hinges

$$M_{(+)} = 0.08 wL^2, M_{(-)} = 0.045 wL^2,$$

$$V_{(+)} = 0.50wL, \text{ and } V_{(-)} = -0.50wL$$

*Vertical Analysis using ACI Coefficients

$$M_{(+)} \text{ (i) For end spans, if discontinuous end is (a) unrestrained } = wL^2/11, \text{ (b) restrained } = wL^2/14$$

$$\text{(ii) For interior spans } = wL^2/16$$

$$M_{(-)} \text{ (i) At the exterior face of first interior supports for (a) Two spans } = wL^2/9, \text{ (b) More spans } = wL^2/10$$

$$\text{(ii) At the other faces of interior supports } = wL^2/11$$

$$\text{(iii) For spans not exceeding } 10', \text{ of where columns are much stiffer than beams } = wL^2/12$$

$$\text{(iv) At the interior faces of exterior supports, if the support is (a) a beam } = wL^2/24, \\ \text{(b) a column } = wL^2/16$$



$$V \text{ (i) In end members at first interior support } = \pm 1.15wL/2, \text{ (ii) At all other supports } = \pm wL/2$$

*Deflection of truss due to load, temperature change and misfit, $\Delta = \sum N_1 dL = \sum N_1 (N_0 L/EA + \alpha \Delta T L + \Delta L)$

*Deflection of beams/frames due to axial, shear and flexural deformation,

$$\Delta = \int (x_1 x_0/EA) dS + \int (v_1 v_0/GA^*) dS + \int (m_1 m_0/EI) dS$$

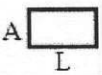
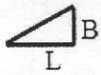
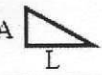
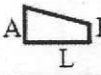
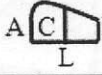
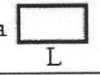
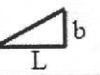
Integration of Product of Functions ($I = \int f_1 f_2 dS$)

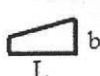
$f_2 \backslash f_1$					
	AaL	$BaL/2$	$AaL/2$	$(A+B)aL/2$	$[A+4C+B]aL/6$
	$AbL/2$	$BbL/3$	$AbL/6$	$[A+2B]bL/6$	$[2C+B]bL/6$
	$AaL/2$	$BaL/6$	$AaL/3$	$[2A+B]aL/6$	$[A+2C]aL/6$
	$A(a+b)L/2$	$B(a+2b)L/6$	$A(2a+b)L/6$	$[A(2a+b)+B(a+2b)]L/6$	$[Aa+Bb+2C(a+b)]L/6$